

# 15 HP DIESEL ENGINE

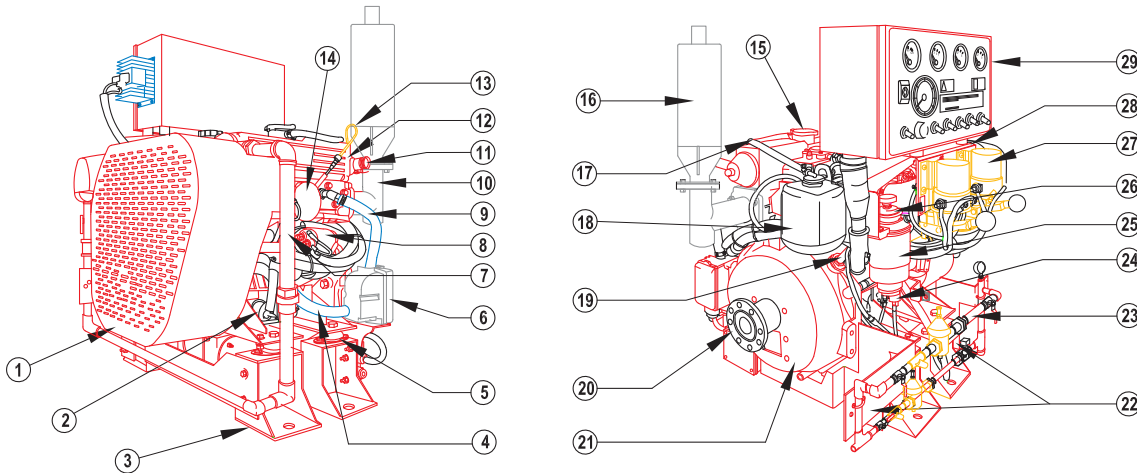

Heat Exchanger Cooled, Naturally Aspirated  
1.12 Liter, 3 Cylinder Engine



## MATERIAL FEATURES & DETAILS

- |                              |   |
|------------------------------|---|
| 1. safety guard front engine | 16. muffler                               |
| 2. oil pressure sensor       | 17. coolant expansion tube                |
| 3. mounting bracket engine   | 18. coolant expansion tank                |
| 4. heater inlet connection   | 19. magnetic pick up (rpm sensor)         |
| 5. vibration pad             | 20. flange fire pump drive                |
| 6. heater assembly           | 21. flywheel housing                      |
| 7. heat exchanger inlet pipe | 22. mounting bracket cooling loop         |
| 8. starter motor             | 23. cooling loop piping                   |
| 9. heater outlet connection  | 24. water separator unit                  |
| 10. exhaust manifold         | 25. fuel filter                           |
| 11. lower coolant tube       | 26. fuel feed pump                        |
| 12. heat exchanger outlet    | 27. battery starter solenoid              |
| 13. dipstick gauge           | 28. isolator pad                          |
| 14. coolant filter           | 29. instrument panel board / terminal box |
| 15. coolant cap              |   |

# MODEL FC 3015-UL

ITEM	DESCRIPTION
Air Filter	Disposable, Dry Type
Alternator	14V, 50 Amps
Coupling	Stub Shaft
Fuel Connections	Flexible, Supply and Return Lines
Fuel Filter	Spin-On Type w/ Water Separator
Fuel Injection System	In-line type, Gear Driven
Engine Heater	230V-AC, 750 Watts
Governor Speed	Constant Speed, Mechanical
Heat Exchanger	Water to Water, Shell to Tube type
Instrumentation Panel	Tachometer, Hourmeter, Water Temperature, Oil Pressure and Two (2) Voltmeters
Lube Oil Filter	Spin-On Type
Manual Start Control	On Instrument Panel
Overspeed Control	Electronic with Reset and Test on Instrument Panel
Raw Water Solenoid Operation	Automatic from Fire Pump Controller and from Engine Instrument Panel
Stop Solenoid	12V-DC Energized to Stop
Starters	ONE (1) 12VDC
Throttle Control	Adjustable Speed Control, Tamper Proof



# MODEL FC 3015-UL

Heat Exchanger Cooled, Naturally Aspirated  
1.12 Liter, 3 Cylinder Engine  
15 HP Diesel Engine

## PERFORMANCE CURVE

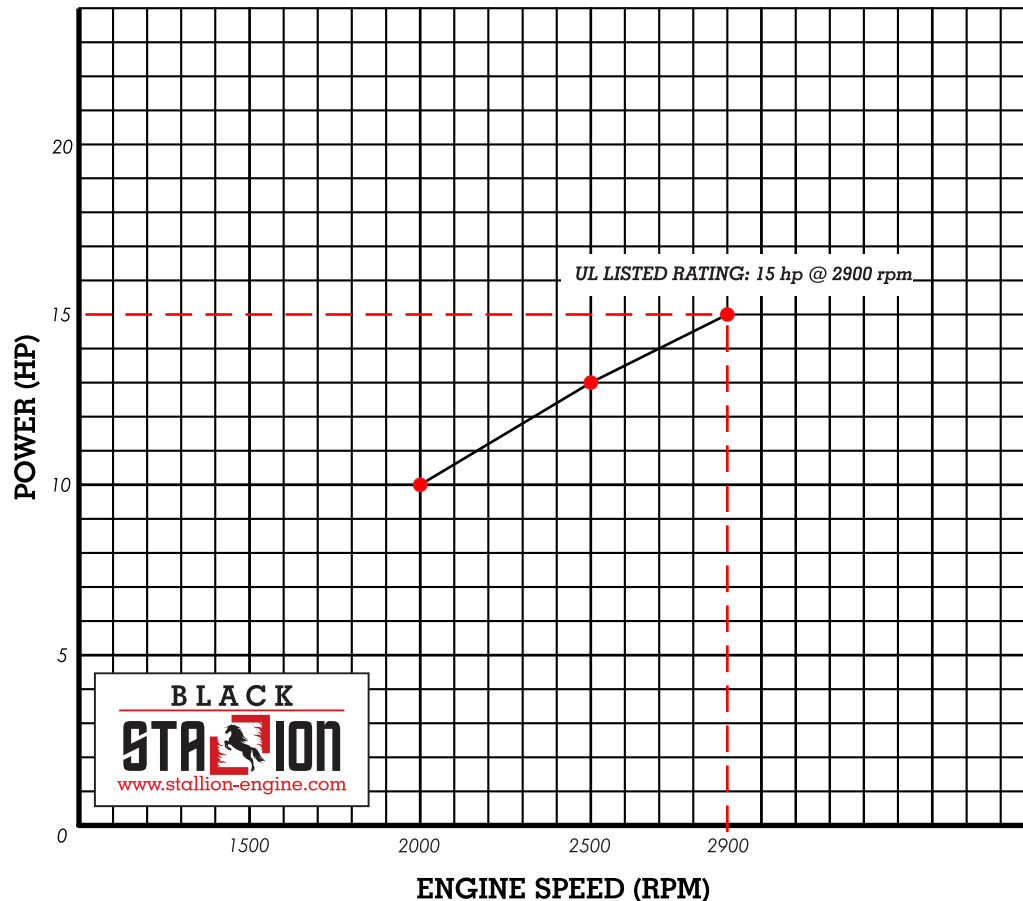

**NOTE:**  
FOR USE IN FIRE PUMP APPLICATIONS ONLY.

## ENGINE SPECIFICATION

ITEM	DESCRIPTION
Speed	2900 RPM
Rated Power	15 HP
Number of Cylinders	3
Aspiration	Naturally Aspirated
Rotation*	Clockwise
Weight – kg (lb)	190 kg. (419.9 lb)
Compression Ratio	-
Displacement	1124 cc
Engine Type	4 Stroke Cycle - Inline Construction
Bore & Stroke	78 mm X 78.4 mm
Fuel Consumption	4.1143 Kg./Hr
Voltage	12 VOLTS
Exhaust Temperature	550°C
Back Pressure	Not more than 15 Kpa
Raw Water Inlet Size	½ inch
Max. Raw Water Pressure	60 psi
Min. Raw Water Flow	3.75 gpm
Water Jacket Heater Size	750 W, 240 VAC

\* ROTATION VIEWED FROM HEAT EXCHANGER/FRONT OF ENGINE

- Each engine is factory tested to verify power and performance.
- Engines are to be used for stationary emergency standby fire pump service only. Engines are to be tested in accordance with NFPA 25.
- Engines are rated at standard SAE conditions of 29.61 in. (752.1 mm) Hg barometer and 77°F (25°C) inlet air temperature (approximates 300 ft (91.4 m) above sea level) by the testing laboratory (see SAE Standard J 1349).
- A deduction of 3 percent from engine horsepower rating at standard SAE conditions shall be made for diesel engines for each 1000 ft. (305 m) altitude above 300 ft. (91.4 m)
- A deduction of 1 percent from engine horsepower rating as corrected to standard SAE conditions shall be made for diesel engines for every 10°F (5.6°C) above 77°F (25°C) ambient temperature.

# MODEL FC 3015-UL

Heat Exchanger Cooled, Naturally Aspirated  
1.12 Liter, 3 Cylinder Engine  
15 HP Diesel Engine

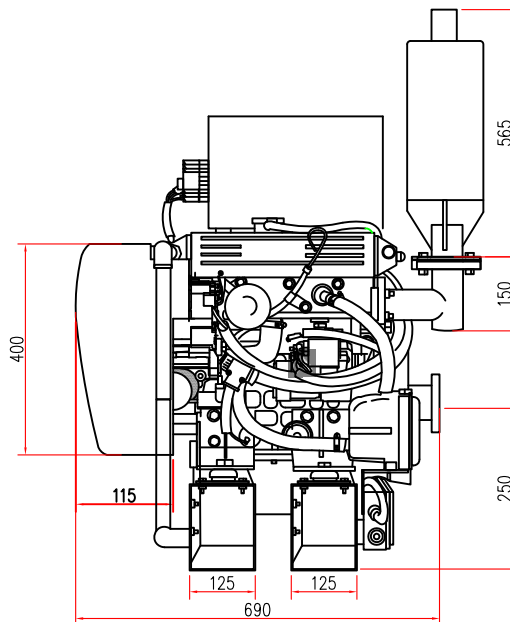
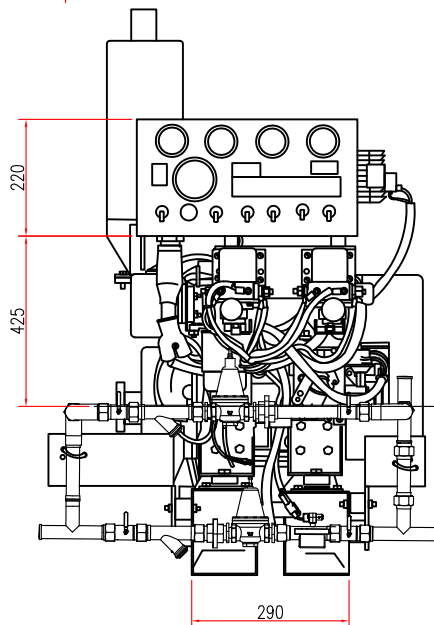
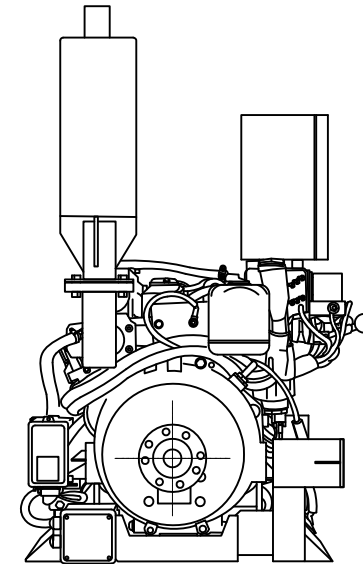
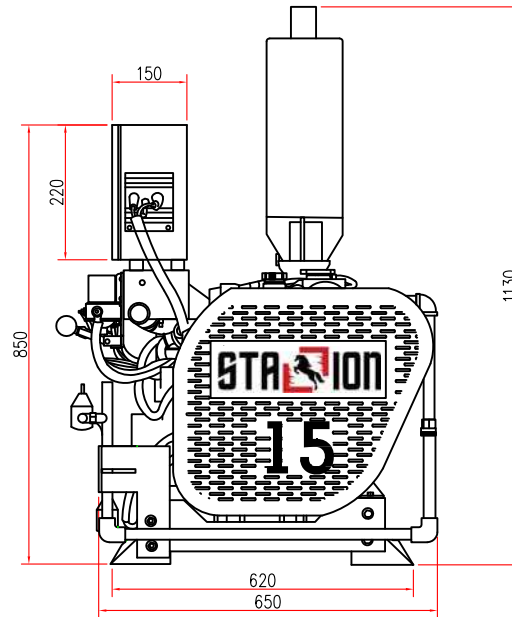
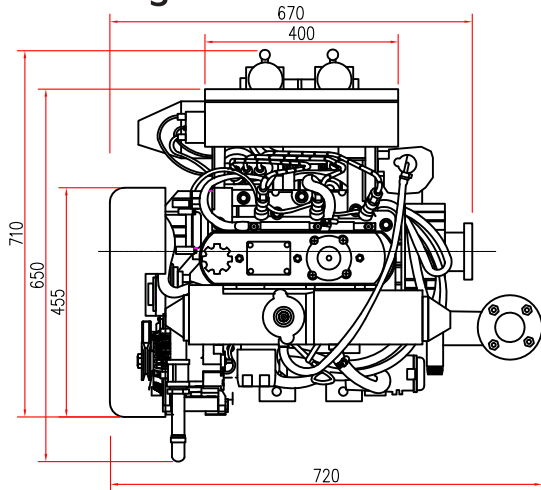

<b>NOMENCLATURE</b>	<b>FC</b>	<b>3015</b>	<b>-UL</b>
	STALLION BASE MODEL	NO. OF CYLINDERS	RAW HP
			UL LISTED

**BLACK**  
**STALLION**  
[www.stallion-engine.com](http://www.stallion-engine.com)

*NOTE:  
DRAWINGS SUBJECT TO CHANGE WITHOUT NOTICE*



**BLACK**  

---

**STALLION**  
[www.stallion-engine.com](http://www.stallion-engine.com)

